

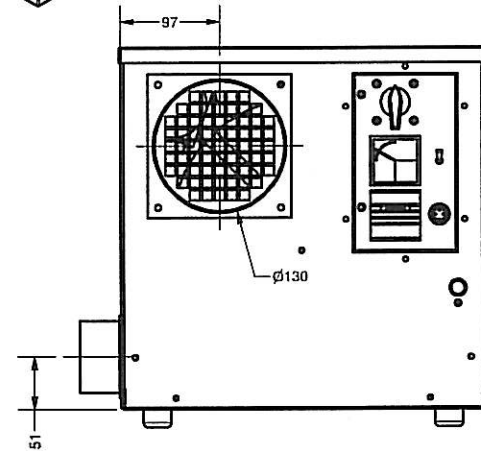

ISS.	DATE	COMMENTS
1	22/11/10	ORIGINAL

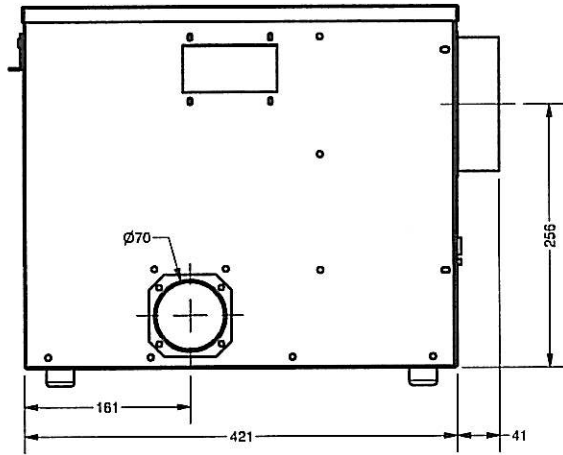
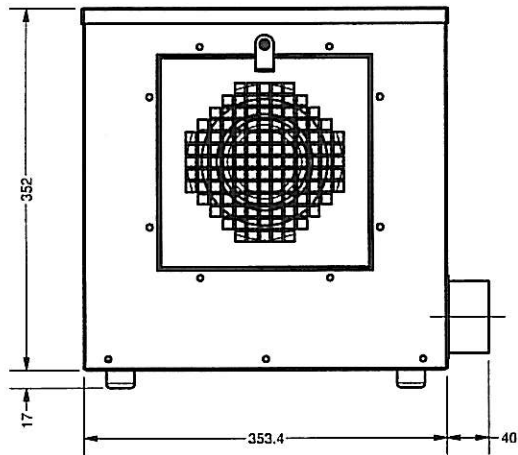
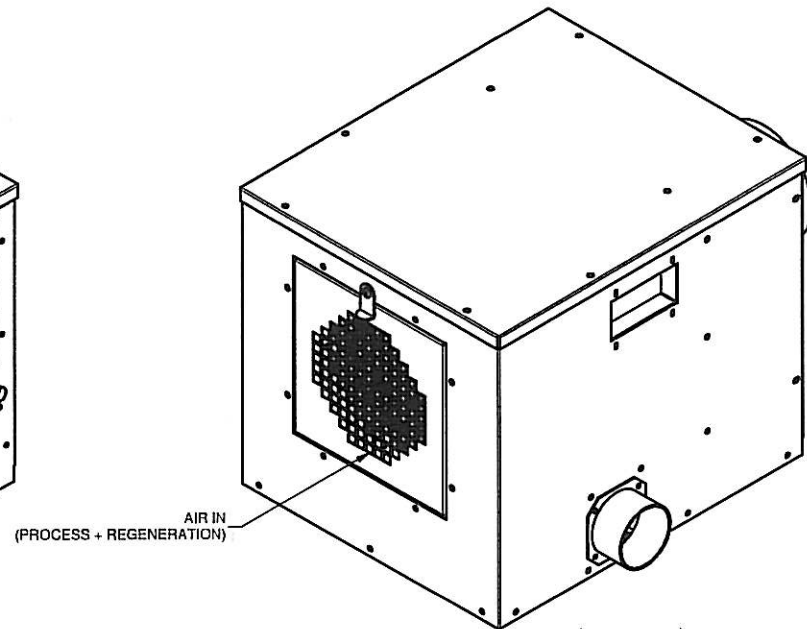
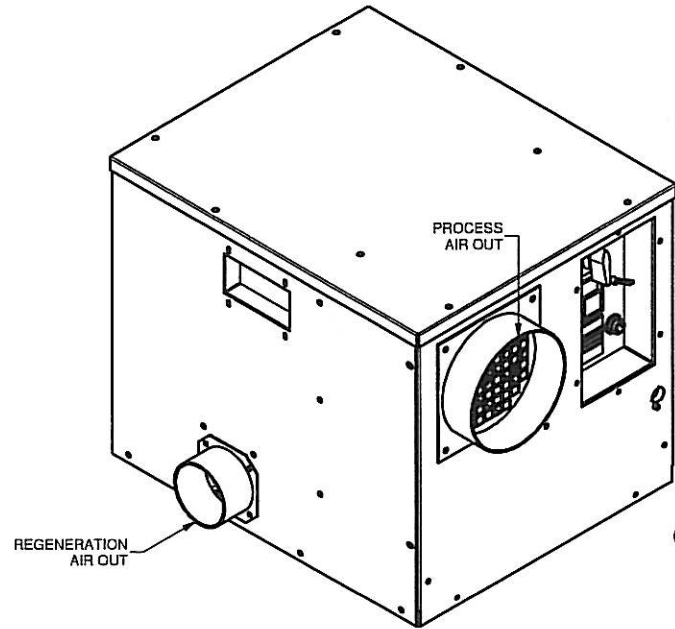

 © 1997 BISIP LTD BISHP AUCKLAND Co. DURHAM ENGLAND	TITLE DD300 GENERAL ASSY	
	MATERIAL N/A	DRAWN : W DAGLISH CAD SCALE : 1/5
DIMENSIONS IN m.m. TOLERANCES UNLESS OTHERWISE STATED 0. ± 1 0.0 ± 0.25 0.00 ± 0.05 ANGULAR ± 0.5 DEGREE	FINISH N/A	DRG.NO. 1050100
3RD ANGLE PROJECTION  DO NOT SCALE IF IN DOUBT ASK		SHEET 1 OF 2

ISS.	DATE	COMMENTS
1	22/11/10	ORIGINAL

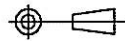
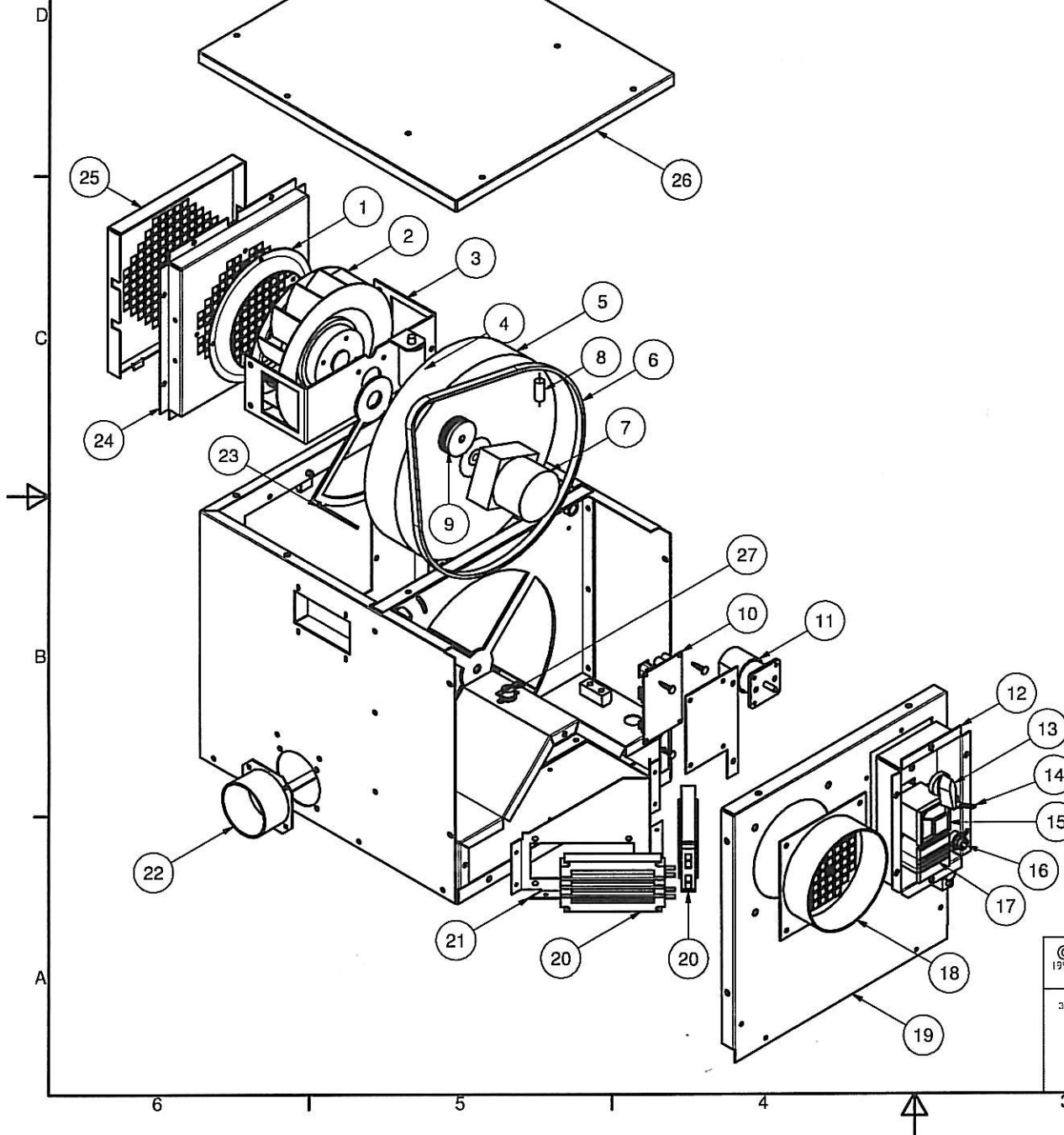

Parts List		
ITEM	DESCRIPTION	QTY
1	MOTR INLET RING	1
2	MOTOR	1
3	MOTOR BRACKET	1
4	MOTOR CAPACITOR	1
5	DESICCANT WHEEL	1
6	DESICCANT WHEEL DRIVE BELT	1
7	DRIVE MOTOR	1
8	DRIVE MOTOR CAPACITOR	1
9	PULLEY	1
10	CONOTL PCB	1
11	ON / OFF SWITCH	1
12	CONTROL BOX	1
13	ON / OFF SWITCH KNOB	1
14	AUTO / MANUAL SELECTION SWITCH	1
15	AMMETER	1
16	EXTERNAL HUMIDISTAT CONNECTOR	1
17	HOURS RUN METER	1
18	PROCESS OUTLET SPIGOT ASSY	1
19	FRONT COVER	1
20	PTC HEATER	2
21	PTC HEATER BRACKET	1
22	REGENERATION OUTLET SPIGOT	1
23	DESICCANT WHEEL SEALING PLATE	1
24	FILTER INLET CAGE	1
25	INLET FILTER RETAINER	1
26	TOP COVER	1
27	OVER HEAT PROTECTOR	1

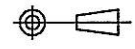
 BISHOP AUCKLAND Co. DURHAM ENGLAND	TITLE		DD300 GENERAL ASSY	
	MATERIAL		DRAWN : W DAGLISH	
3RD ANGLE PROJECTION  DO NOT SCALE IF IN DOUBT ASK	DIMENSIONS IN m.m. TOLERANCES UNLESS OTHERWISE STATED 0. ± 1 0.0 ± 0.25 0.00 ± 0.05 ANGULAR ± 0.5 DEGREE		CAD SCALE : 1/5	
	FINISH		DRG.NO. SHEET	
		1050100		2 OF 2